

# high-tech line

MULTI 800 - 1300 - 2500 - 4000 - 5800

**: multifunction pump  
for water recirculation**



**multi** > Pompa multifunzione per il ricircolo dell'acqua



**ENG** From the 800 lt/h model to the powerful 5800 lt/h model, the Multi line comprises five recirculating pumps for every type of pond up to 10,000 litres. Built according to the strictest international safety regulations, they operate in Wet & Dry mode (except the 800 model), are easy to maintain and are surprising for their high performance and reliability. The 2500-4000-5800 models of the Multi line may be combined with the Eco Max internal filter for ponds or associated with a sponge pre-chamber in order to create waterfalls and pleasant water effects in the pond.

**I** Dal modello 800 al potente modello 5800 la linea Multi comprende cinque pompe da ricircolo per ogni tipo di acquario, fontana o laghetto. Costruite secondo le più severe norme internazionali di sicurezza, funzionano in modalità Wet & Dry (escluso mod. 800), sono di facile manutenzione e sorprendono per le elevate prestazioni ed affidabilità. I modelli 2500-4000-5800 possono essere abbinati al filtro interno per laghetti Eco Max o associati ad una precamera spugna per creare cascate e suggestivi giochi d'acqua all'interno di un laghetto.



### NRG SYSTEM SICCE

The NRG system is a revolution in the sector of permanent magnet synchronous motors and allows you to obtain exceptional power, reduced consumption, great reliability and very low noise levels.

Il sistema NRG è una rivoluzione nel settore dei motori sincroni a magneti permanente e consente di ottenere potenze eccezionali, ridotti consumi, grande affidabilità ed i più bassi livelli di rumorosità.



### WET AND DRY APPLICATION

The WET & DRY application permits the models of the MULTI (except the smallest mod. 800) to be utilized whether they are completely submersed or outside of the water. When operating out of the water, the pump does not overheat as a result of the research during the designing of the surfaces and materials. The static seals do not present any problems of water loss and in the case of impeller blockage or malfunction, a reversible thermal protector stops the flow of current to the motor, preventing any possible damage of the pump.

L'applicazione WET & DRY permette di impiegare i modelli della linea multi (eccetto il più piccolo mod. 800) sia completamente immersa sia fuori dall'acqua. Fuori dall'acqua la pompa non si surriscalda grazie allo studio in fase di progettazione delle superfici e dei materiali. Grazie alle tenute statiche la pompa non presenta nessun problema di perdita d'acqua e nel caso di guasto o malfunzionamento un protettore termico reversibile interrompe l'alimentazione, impedendo qualsiasi danneggiamento della pompa.



### AIR MIX SYSTEM

The pre-chamber accessory with Air Mix system available for 2500, 4000, 5800 models (optional) allows large quantities of air to be mixed with the water, considerably increasing the concentration of Oxygen (O<sub>2</sub>).

L'accessorio precamera con sistema Air Mix disponibile per i modelli 2500, 4000, 5800 (optional) consente di miscelare grandi quantità di aria con l'acqua, aumentandone sensibilmente la concentrazione di Ossigeno (O<sub>2</sub>).



Multi 5800  
with Air Mix System  
(optional)





Thanks to the NRG System no mechanical parts for controlling the impeller direction are required.

PATENTED

# high-tech line

Ceramic shaft  
(except mod. 800-1300)



NRG powered  
(except mod. 800-1300)

Threaded intake/discharge  
(except mod. 800)

Strong case

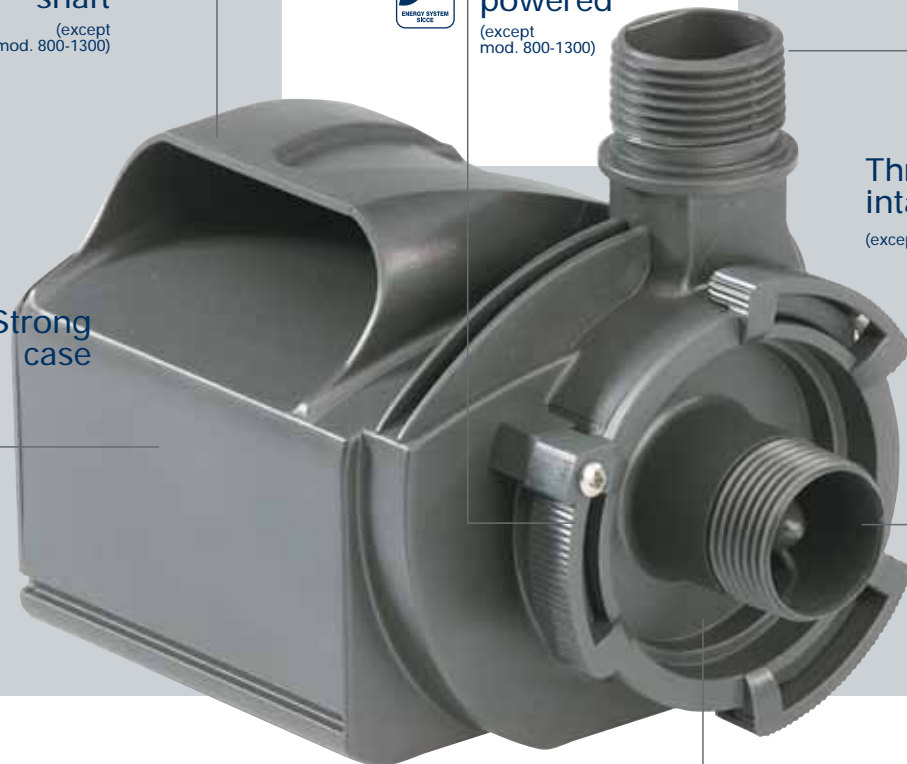

Wet & Dry Application  
(except mod. 800)

AQUARIUM



FOUNTAIN



POND





# high-tech line

multi



H-m

Multi 800  
Multi 1300  
Multi 2500  
Multi 4000  
Multi 5800

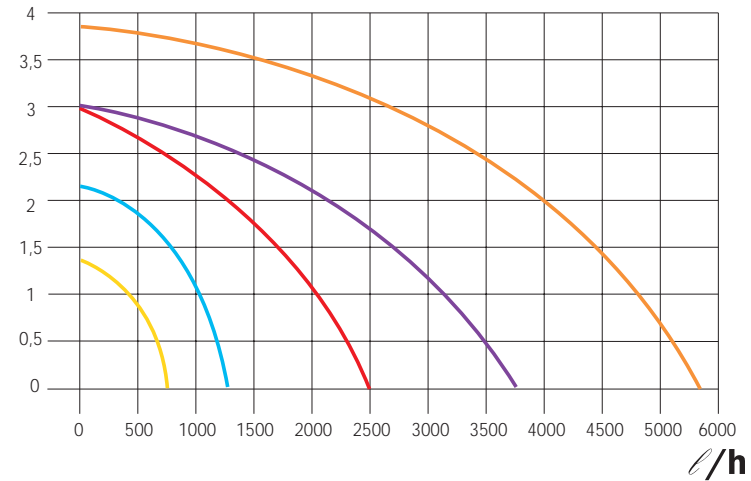



**MULTI 800**  
1,5 m cable



**MULTI 800**  
10 m cable



**MULTI 1300**  
1,5 m cable



**MULTI 1300**  
10 m cable



**MULTI 2500 - 4000**  
1,5 m cable



**MULTI 2500 - 4000**  
10 m cable



**MULTI 5800**  
1,5 - 10 m cable

FLOW REGULATOR INCLUDED

Included								
	HOSE CONNECTOR	LONG PRECHAMBER	HOSE CONNECTOR AND SPONGE	HOSE CONNECTOR LONG PRECHAMBER	HOSE CONNECTOR	HOSE CONNECTOR LONG PRECHAMBER	HOSE CONNECTOR	HOSE CONNECTOR
Optional								
						AIR MIX PRECHAMBER	AIR MIX PRECHAMBER	AIR MIX PRECHAMBER
Packaging								



Packaging dimensions	Length	Depth	Height
	Multi 800-1300 1,5 m cable	125 mm	122 mm
Multi 800-1300 10 m cable	188 mm	120 mm	200 mm
Multi 2500-4000 1,5 m cable	188 mm	120 mm	150 mm
Multi 5800 1,5 m cable	188 mm	120 mm	150 mm
Multi 2500-4000-5800 10 m cable	188 mm	120 mm	150 mm





# high-tech line

Aquarium application



Fountain application

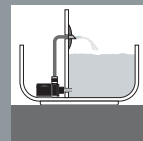

Pond application

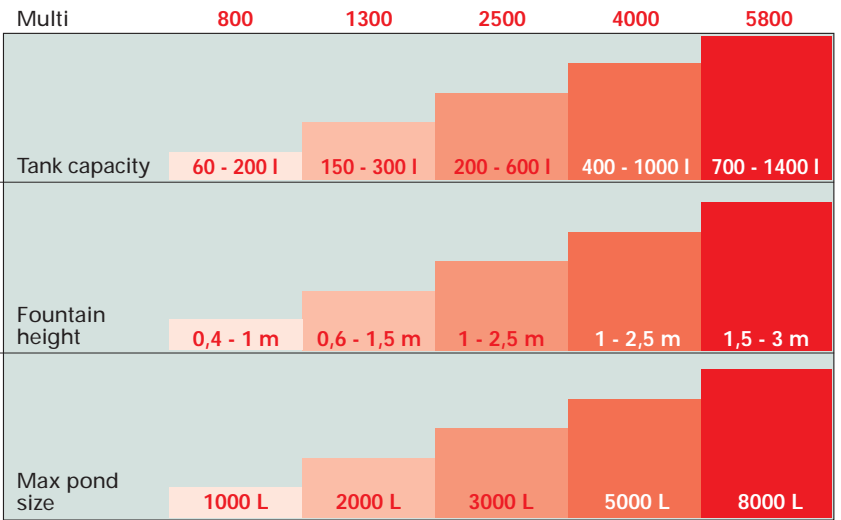
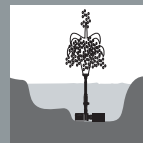

**Multi\_800**

Volt 230 ~	Volt 120 ~
Hz 50	Hz 60
Watt 13	Watt 13,8
A 0,1	A 0,24
H-m 1.30	Feet 4.4
l/h 800	gph 220

**Multi\_1300**

Volt 230 ~	Volt 120 ~
Hz 50	Hz 60
Watt 20	Watt 25
A 0,2	A 0,4
H-m 1.70	Feet 6.0
l/h 1200	gph 320

**Multi\_2500**

Volt 230 ~	Volt 120 ~
Hz 50	Hz 60
Watt 55	Watt 40
A 0,51	A 0,66
H-m 3.10	Feet 10.5
l/h 2500	gph 715

**Multi\_4000**

Volt 230 ~	Volt 120 ~
Hz 50	Hz 60
Watt 67	Watt 48
A 0,64	A 0,79
H-m 3.10	Feet 10.5
l/h 3800	gph 990

**Multi\_5800**

Volt 230 ~	Volt 120 ~
Hz 50	Hz 60
Watt 90	Watt 142
A 0,8	A 2,97
H-m 3.80	Feet 12
l/h 5800	gph 1500



Models available in low voltage please contact us for specifications.

Also for pool and spa applications



## multi 800

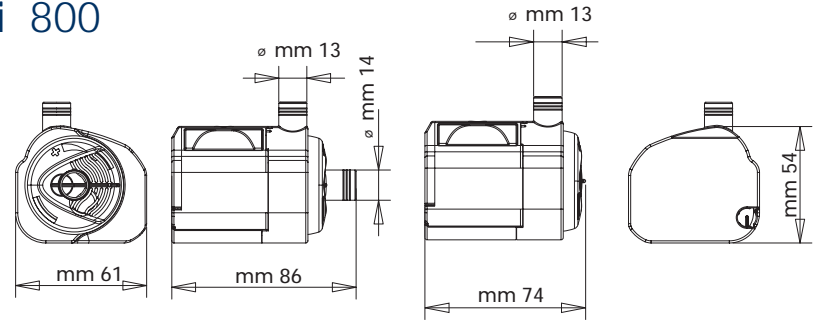

## multi 1300

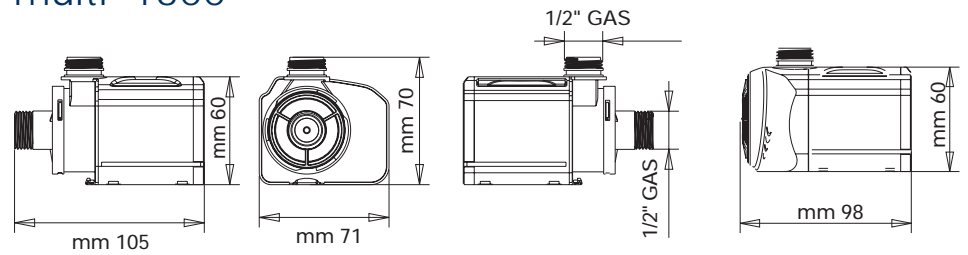



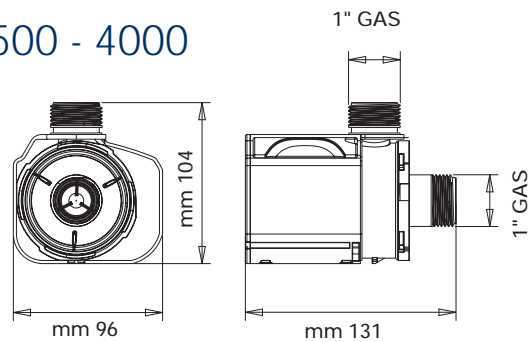



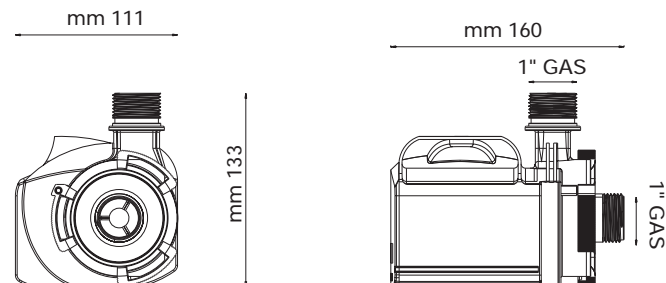



























## multi 2500 - 4000



## multi 5800



MULTI	APPLICATION	PLUS
800	 	 
1300	  	  
2500	  	    
4000	  	    
5800	  	    



Aquarium application



Pebble application













Fountain application



Pond application

## : Accessories - Spare parts

Multi		800	1300	2500	4000	5800
<b>Spare Parts</b>						
<b>ROTOR</b>		<b>90209</b> (230-240V) <b>SGR0002</b> (120V)	<b>SGR0003</b> (230-240V) <b>SGR0004</b> (120V)	<b>SGR0005</b> (230-240V) <b>SGR0006</b> (120V)	<b>SGR0005</b> (230-240V) <b>SGR0006</b> (120V)	<b>SGR0008</b> (230-240V) <b>SGR0009</b> (120V)
<b>CERAMIC SHAFT</b>				<b>SGR0007</b>	<b>SGR0007</b>	<b>SGR0010</b>
<b>SPONGE</b>		<b>SSP0003</b>				
<b>O-Rings</b>		<b>SKT0019</b>	<b>SKT0020</b>	<b>SKT0021</b>	<b>SKT0021</b>	<b>SKT0022</b>
<b>HOSE CONNECTOR</b>		<b>SPL0004</b>	<b>STR0001</b>	<b>STR0002</b>	<b>STR0002</b>	<b>STR0003</b>
<b>Accessories</b>						
<b>PRECHAMBER</b> with flow regulator		<b>SPL0003</b>	<b>SPL0007</b>			
<b>LONG PRECHAMBER</b>		<b>SPL0005</b> (+ sponge)	<b>SPL0006</b>	<b>SPL0008</b>	<b>SPL0010</b>	<b>SPL0012</b>
<b>FLAT PRECHAMBER</b>				<b>SPL0009</b>	<b>SPL0011</b>	
<b>AIR MIX KIT</b> with prechamber				<b>SKT0031</b>	<b>SKT0032</b>	<b>SKT0033</b>
<b>WATER PLAYS KIT</b> (Waterbell + Daisy)				<b>SKT0030</b>	<b>SKT0030</b>	<b>SKT0030</b>

WE RESERVE THE RIGHT TO MODIFY THE TECHNICAL DATA WITHOUT WARNING.

: **SICCE S.p.A.** - Via V. Emanuele, 115  
 36050 Pozzoleone (Vicenza) - ITALY  
 Tel: +39 0444 462826 Fax +39 0444 462828  
 www.sicce.com - info@sicce.com